

OS-LDC-A01

Wireless Symphony LED Controller

Product Specifications



This product warranty is 2 years (exclude the artificial situation of damaged or overload working)

Before installing this product , Please read this manual carefully. Ensure full understanding of this specification to avoid unnecessary damage and additional costs.

Product Description

Wireless Symphony LED Controller (OS-LDC-A01) is suit for UCS1903 (TM1804 etc) output applications which drive LED directly. It is widely used in advertising, stage sets, home decorations, etc. It has many advantages such as low price, easy connection and simplicity to use. It has a memory function. Meanwhile, you could adjust brightness, static color choices and various dynamic changes in lighting effects through wireless remote control. It can also be used as a synchronous controller. That is to say you can synchronously control number of decoders and LED lights.

External Dimension

(Controller)



(Remote control)



(Packing size)

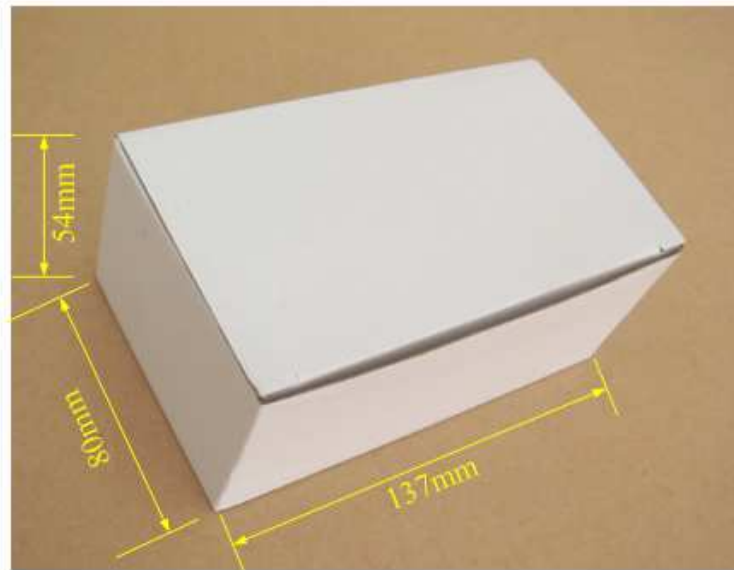

Technical Parameters

Working temperature	-20-60°C
Supply voltage	DC12V
Current	<60mA
External dimension	L137*W70*H25 mm
Packing size	L137*W80*H54mm
Net weight	180g
Gross weight	270g
Effects model	133
Maximum control points	1024 (Low-speed) points, 2048 (High-speed) points
Controlled IC Model	Such as the TM1803, TM1804, TM1809, UCS1903 etc. (specify the required model on orders)

Interface Specifications

Power input interface (port1) :



Adopt conventional power transposon as a DC power input interface.

Power input interface (port2) :

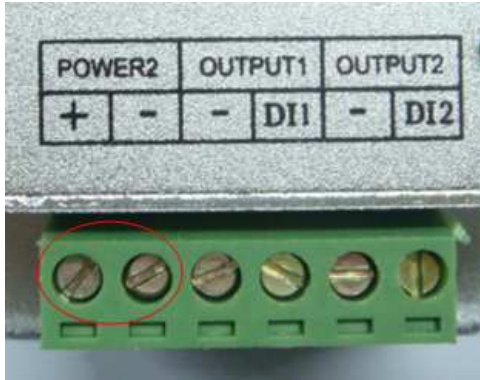

Adopt male and female connector with screw.

Synchronization interface:



Adopt Standard network line interface.

Signal output interface:

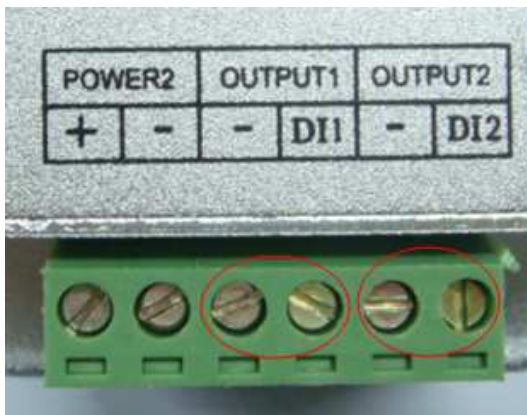

Adopt male and female connector with screw.

Direction for use

- Connect the load well wire at first, following by the power wire; **Please ensure short circuit can not occur between connecting wire before you turn on the power. Then set the steps as follows.**
- Press the "On / off" button to take the controller off before setting the menu.
- Press the "up", "down" button one time at the time, and LED would be bright at this moment. Then press the "Mode / Speed" button to get into the menu settings screen.
- The first setting screen is for "High-speed, low-speed settings", and the LED would display "S-HI" or "S-LO". Then press the "up" and "down" button to select the mode. (If the IC on the light bar is high-speed mode, you should choose "S-HI", and choose "S-HI" when low-speed.) The factory default is for the high-speed mode.
- Continue to press the "Mode / Speed" button to enter the second screen-"Control points setting".

The LED display 4-digit is for the number of control points. To plus or minus the number by pressing the “up” and “down” button (Long pressing can adjust quickly). The factory default is for 50.

- After setting well, press the "On / off" button to save and exit.
- There are 4 buttons in total on the control panel, function of each button as below:



- ★ **On/off** : It can open or close output.
 - ★ **Mode/Speed** : Mode adjustment / speed adjustment function switch (The first LED displays H for model adjustment, shows S for the speed adjustment.)
 - ★ **UP** : Mode+/Speed+ button. When in mode regulator function, it is for “Mode+”. When in speed regulator function, it is for “Speed+”.
 - ★ **DOWN** : Mode-/Speed- button. When in mode regulator function, it is for “Mode-”. When in speed regulator function, it is for “Speed-”.
- Adopt wireless control method, 4keys in total, function of each key as below :

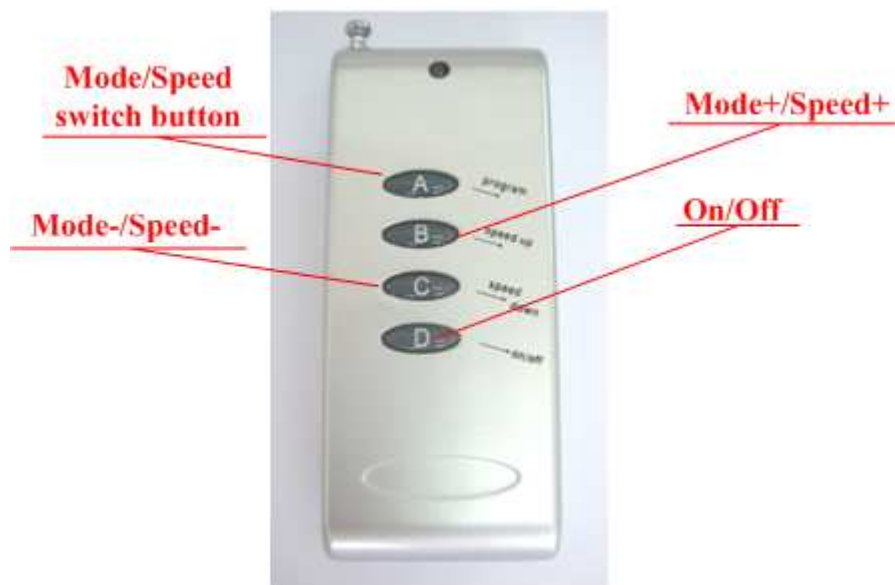

- ★ **A:** Mode adjustment / speed adjustment function switch (The first LED displays H for model adjustment, shows S for the speed adjustment.)
- ★ **B :** Mode+/Speed+ button. When in mode regulator function, it is for “Mode+”. When in speed regulator function, it is for “Speed+”.
- ★ **C :** Mode-/Speed- button. When in mode regulator function, it is for “Mode-”. When in speed regulator function, it is for “Speed-”.
- ★ **D : On/Off button:** It can open or close output.

Note: After powering, the red light would bright. And each press, the green light flash one time.

- Synchronous controller system description

Synchronous control system can be made of any number of controller connections. Each of the sub-controller would follow to the first master controller to achieve a permanent synchronous change. And there is not delay.

After connecting the wiring diagram, the sub-controller need not be set. It will be in accordance with the master to controlling the speed and mode change. (That would be not synchronous when powering. You could close and open to be synchronous) When master is working, and the sub-control working well, the green signal light of sub-control would flick. The digital LED display the mode in operation.

- Standard color changes as follows:

NO.	Function Description	NO.	Function Description
1	Static red	2	Static green
3	Static blue	4	Static yellow
5	Static cyan	6	Static purple
7	Static white	8	Three color jumpy change
9	Seven color jumpy change	10	Seven color stroboflash
11	Red horse race lamp to right direction	12	Purple horse race lamp to left direction
13	Blue horse race lamp to right direction	14	Cyan horse race lamp to left direction
15	Seven color cycling horse race lamp to right direction	16	Seven color cycling horse race lamp to left direction
17	Seven color horse race lamp back-for-ward direction	18	Seven color horse race lamp to left direction
19	Seven color jumping horse race lamp to right direction	20	Three color gradually change
21	Seven color gradually change	22	Red background scan lamp back-for-ward direction
23	Green background scan lamp back-for-ward direction	24	Blue background scan lamp back-for-ward direction
25	Yellow background scan lamp back-for-ward direction	26	Cyan background scan lamp back-for-ward direction
27	Purple background scan lamp back-for-ward direction	28	White background scan lamp back-for-ward direction

29	Seven color scan lamp back-for-ward direction	30	Red water move to right direction
31	Red water move to left direction	32	Green water move to right direction
33	Green water move to left direction	34	Blue water move to right direction
35	Blue water move to left direction	36	Yellow water move to right direction
37	Yellow water move to left direction	38	Cyan water move to right direction
39	Cyan water move to left direction	40	Purple water move to right direction
41	Purple water move to left direction	42	White water move to right direction
43	White water move to left direction	44	Seven color cycling water move to right direction
45	Seven color breathing lamp back-for-ward direction	46	Red trail to left single direction
47	Purple trail to left single direction	48	Blue trail to left single direction
49	Cyan trail to left single direction	50	White trail to left single direction
51	Green trail to left single direction	52	Yellow trail to left single direction
53	Seven color jumping trail to left single direction	54	Seven color queue trail to left single direction
55	Seven color alternation trail to left single direction	56	Red trail to right single direction
57	Purple trail to right single direction	58	Blue trail to right single direction
59	Cyan trail to right single direction	60	White trail to right single direction
61	Green trail to right single direction	62	Yellow trail to right single direction
63	Seven color jumping trail to right single direction	64	Seven color queue trail to right single direction
65	Seven color alternation trail to right single direction	66	Red water trail to right direction
67	Purple water trail to right direction	68	Blue water trail to right direction
69	Cyan water trail to right direction	70	White water trail to right direction
71	Green water trail to right direction	72	Yellow water trail to right direction
73	Seven color jumping water trail to right direction	74	Seven color queue water trail to right direction
75	Seven color alternation water trail to right direction	76	Red trail to left double direction
77	Purple trail to left double direction	78	Blue trail to left double direction
79	Cyan trail to left double direction	80	White trail to left double direction
81	Green trail to left double direction	82	Yellow trail to left double direction
83	Seven color jumping trail to left double direction	84	Seven color queue trail to left double direction
85	Seven color alternation trail to left double direction	86	Red trail to right double direction
87	Purple trail to right double direction	88	Blue trail to right double direction
89	Cyan trail to right double direction	90	White trail to right double direction
91	Green trail to right double direction	92	Yellow trail to right double direction
93	Seven color jumping trail to right double direction	94	Seven color queue trail to right double direction
95	Seven color alternation trail to right double direction	96	Full color wave to right direction
97	Seven color water move to left direction	98	Purple background trail to right double direction
99	Blue background trail to right double direction	100	White background trail to right double direction
101	Cyan background trail to right double direction	102	Green background trail to right double direction
103	Yellow background trail to right double direction	104	Seven color background trail to right double direction
105	Seven color spread from the middle to both sides	106	Seven color breathing from the middle to both sides
107	Seven color draw curtain	108	Seven color lower curtain
109	Seven color spread from both sides to the middle	110	Colorful switch
111	Seven color overlay to right direction	112	Seven color overlay to left direction
113	Seven color overlay to left and right direction	114	Seven color background overlay to double direction
115	Seven color overlay from middle to both sides	116	Seven color background overlay middle to both sides
117	Seven color overlay from both sides to middle	118	Seven color background overlay both sides to middle
119	Sub seven color move back-for-ward direction	120	Sub seven color jump and move back-for-ward
121	Sub seven color background move back-for-ward	122	Sub seven color background move single direction
123	Sub seven color overlay to left and right direction	124	Sub seven color background overlay to left and right
125	Sub seven color spread to single direction	126	Sub seven color spread back-for-ward
127	Sub seven color water move to left and right	128	Sub seven color spread from middle to both sides
129	Sub seven color stretch from middle to both sides	130	Sub seven color stretch to single direction
131	Sub seven color overlay to single direction	132	Auto play circularly
133	Custom combination mode		

Typical Applications

Application Circuit1:

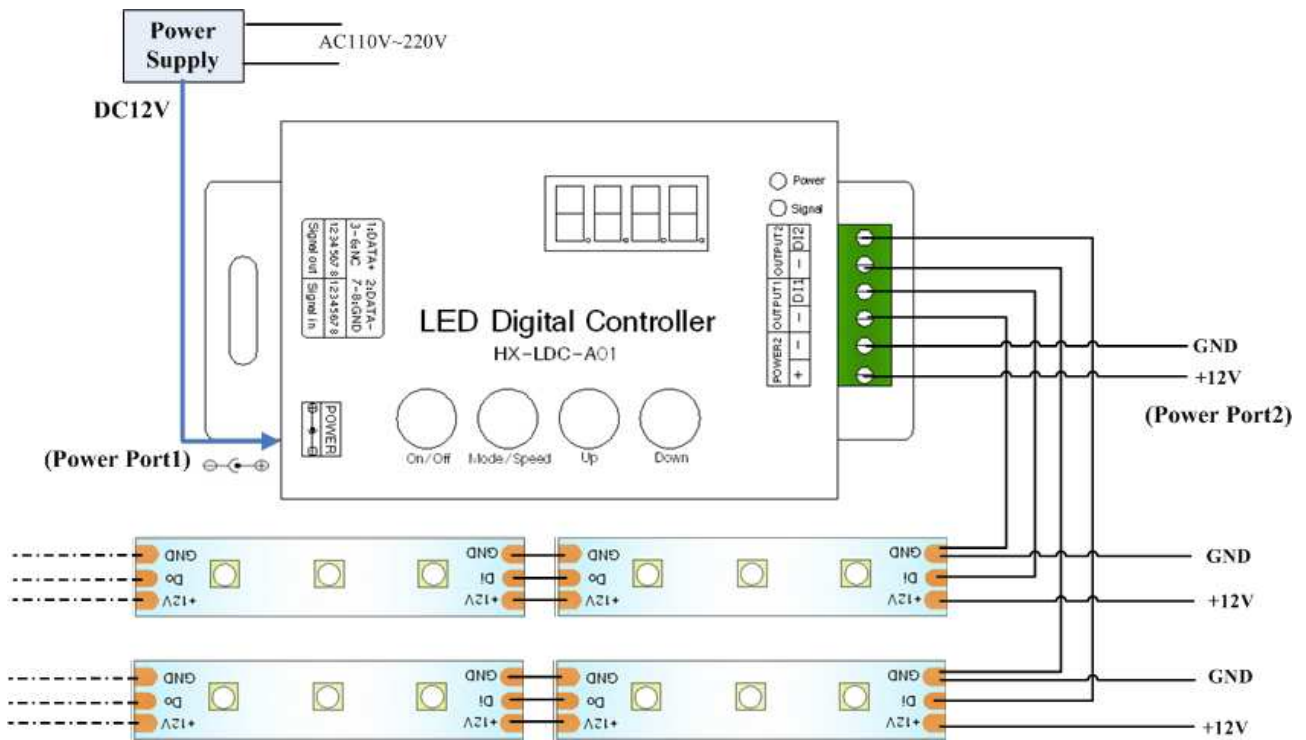

Application Circuit2, (Each controller can be individually powered, can also share power)

Application of synchronization:

Wireless Symphony LED Controller(HX-LDC-A01)

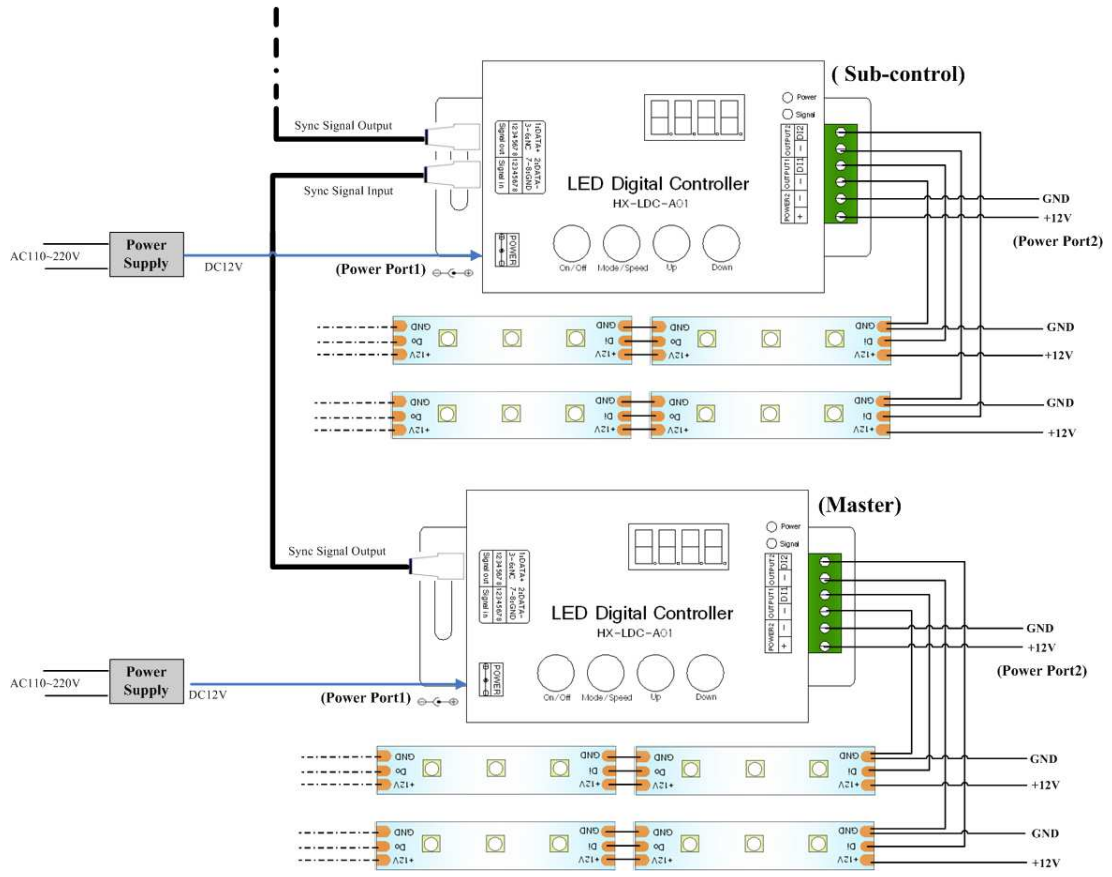

(Cascade Connection)

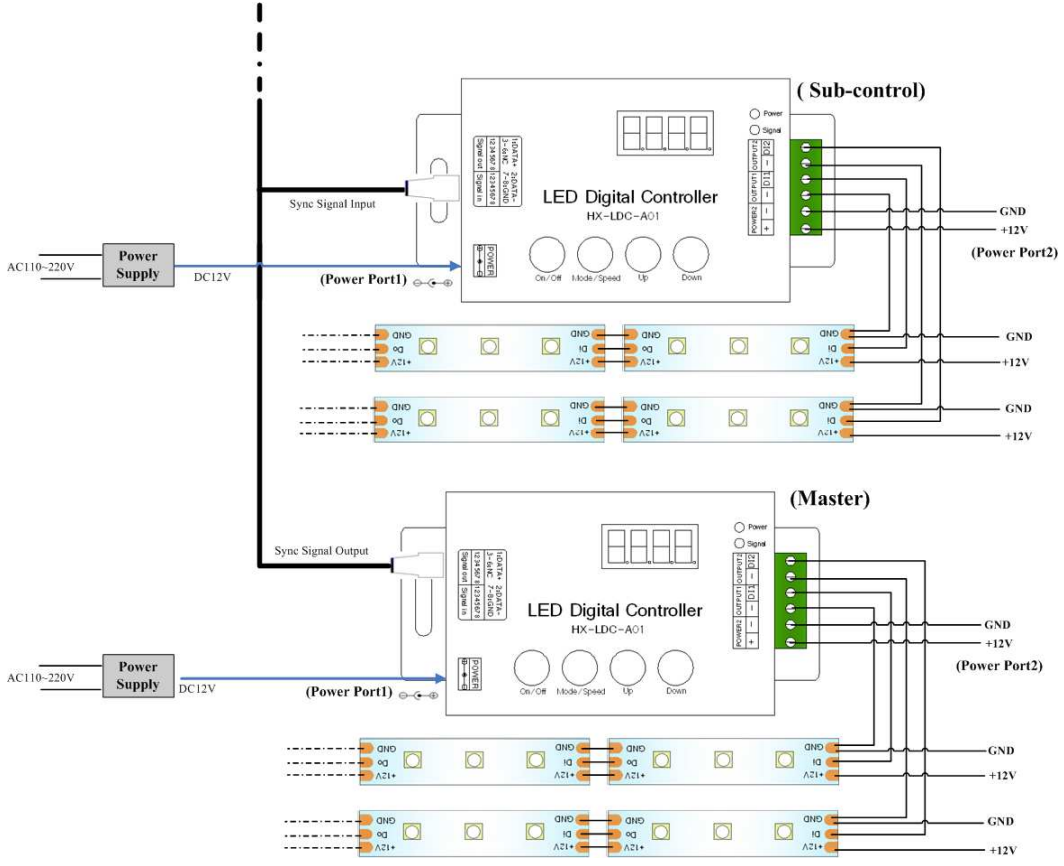

(Bus connection)



Notes

1. Supply voltage of this product is DC12VV, never connect to others or AC220V.
2. Wireless Remote Control is powered by DC12V battery, if Stretch the antenna, it would Control better.
3. Lead wire should be connected correctly according to grade that connecting diagram offers.
4. If the load is more, by way of port 2 to connect the power will be better.
5. This product is not to overload;
6. Warranty of this product is three years, but exclude the artificial situation of damaged or overload working.

Common Problems

Problems	Possible cause	Solution
1. Lamp does not light after power, or it does not work well.	Power wire is not properly connected, or the switching power supply hasn't output.	Connect the power cord properly or replay the power
	Power wire or signal wire are not connected or it is short circuit	Connected power wire or signal wire well.
	Controller is not set well.	Please see instructions.
2. In the use of synchronization, the light bar is not synchronized.	The controller is not installed properly.	Please see instructions.